 <p>Induction Lamp: flood MG-F02</p>	Power Consumption	150/200
	Working Voltage	110/220/277
	Luminous Flux	6400/8600
	Certifications	CE, UL, FCC IEC/EN 60598, CB, CCC, IP65
	Beam Spread	
	Replaces	HID – 250W/400W
	Colour Temperature	2700(UW)/3500(W)/5000(D)/6500(UD)

Special Features

1. Die cast aluminium ballast housing finished in light black.
2. Hinged diffuser cover for ease of access to lamp and control gear.
3. Stainless Steel external fasteners
4. Mechanical clamps to ensure IP integrity
5. 4mm toughened tempered diffuser
6. UV anti-ageing silicon gasket
7. Reflectors made of high purity aluminum with up to 80% reflectance
8. Angle adjustable mounting bracket.
9. 4mm toughened tempered diffuser.

Optional:

1. Nano-Grade reflector with up to 94% of direct and diffused reflectance.
2. Frost glass/PC diffusers.

Installation:

Supplied with a mounting bracket for anchor fixing

Applications:

Building Landscape / Car Park / Billboards / Indoor Stadium / Tennis Court /
Swimming Pool / Outdoor Areas

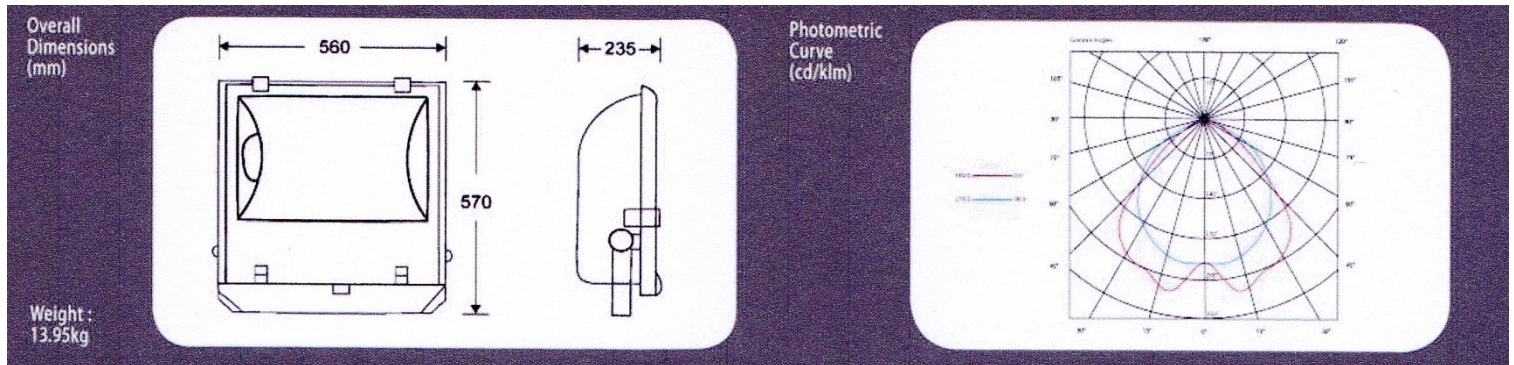

Product Code	Wattage (W)	Colour Temperature (K)	Operating Voltage (V)	Ambient Temperature (°C)	Luminaire Dimensions (Ø x H mm)	Note
MG-F02Q150W	150	6500 (UD) 5000 (D)	110/220/277	-15~40	570x560x235	Optional Diffusers: Frost glass (F), PC (P), Optional Reflector: Nanoflex (NF)
MG-F02Q200W	200	3500 (W) 2700 (UW)				

Ordering code: MG-F02Q 150W/200W-UD/D/W/UW -F/P/NF

Applications: Building Landscape / Car Park / Billboards / Indoor Stadium / Tennis Court /
Swimming Pool / Outdoor Areas